

SCHEMATIC DIAGRAM (1/2)

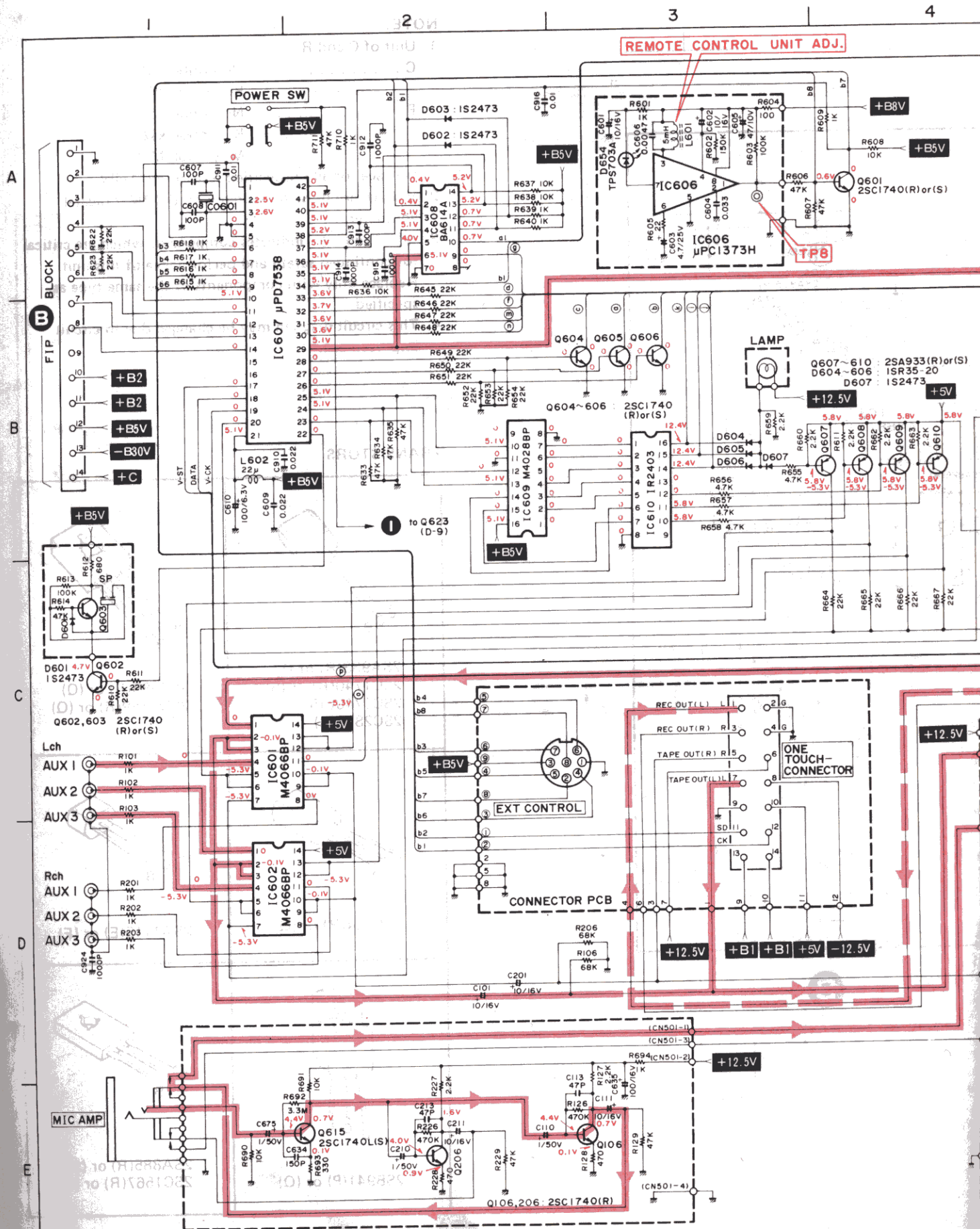

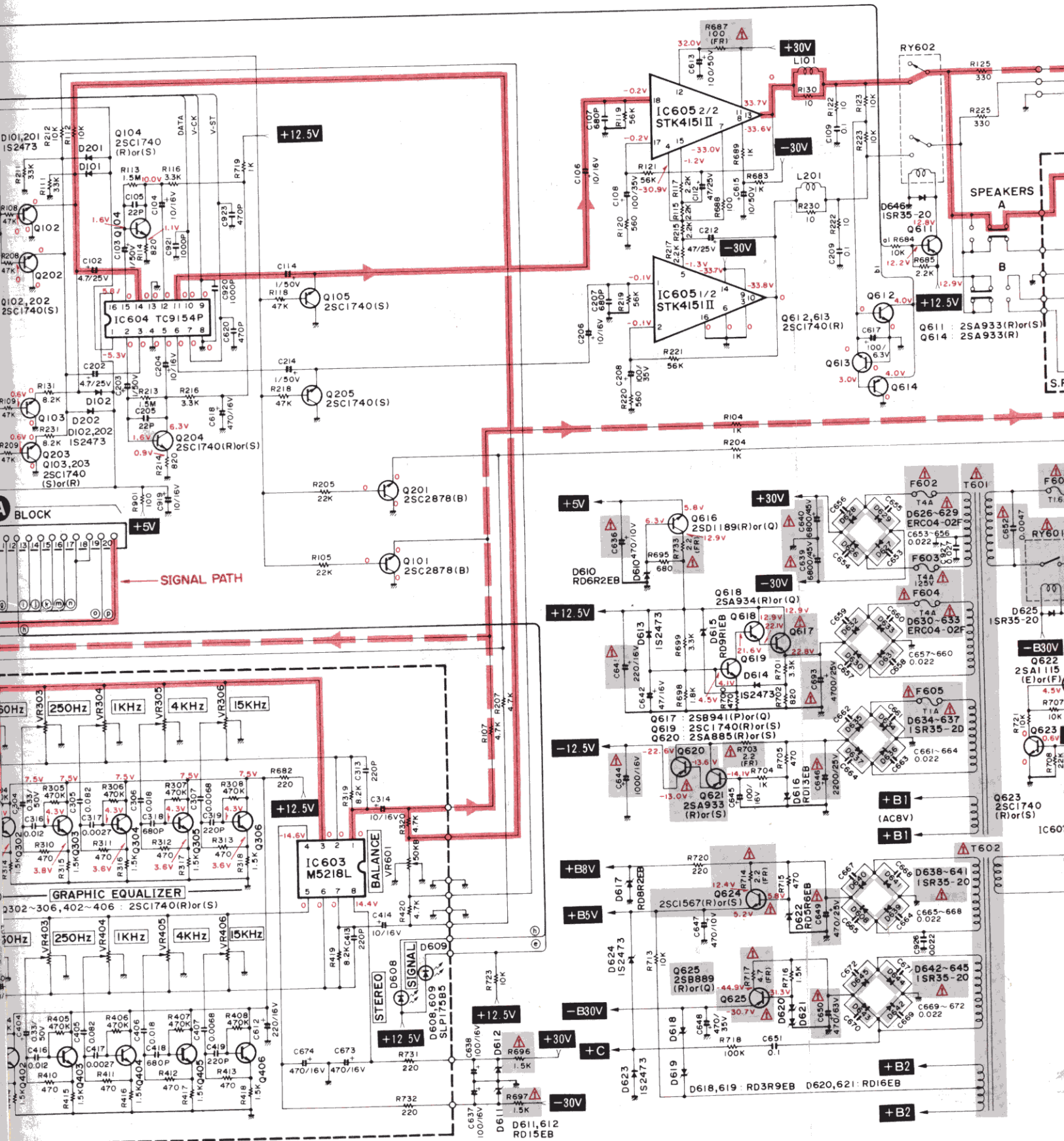

8

9

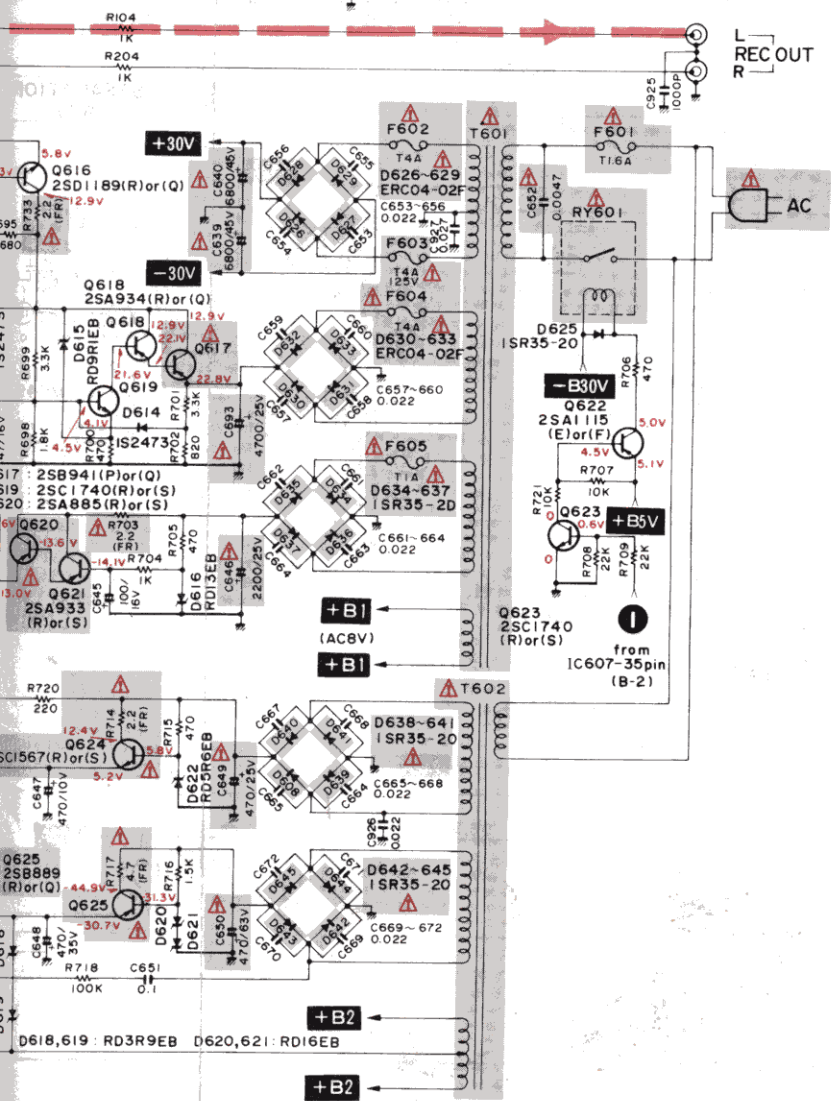
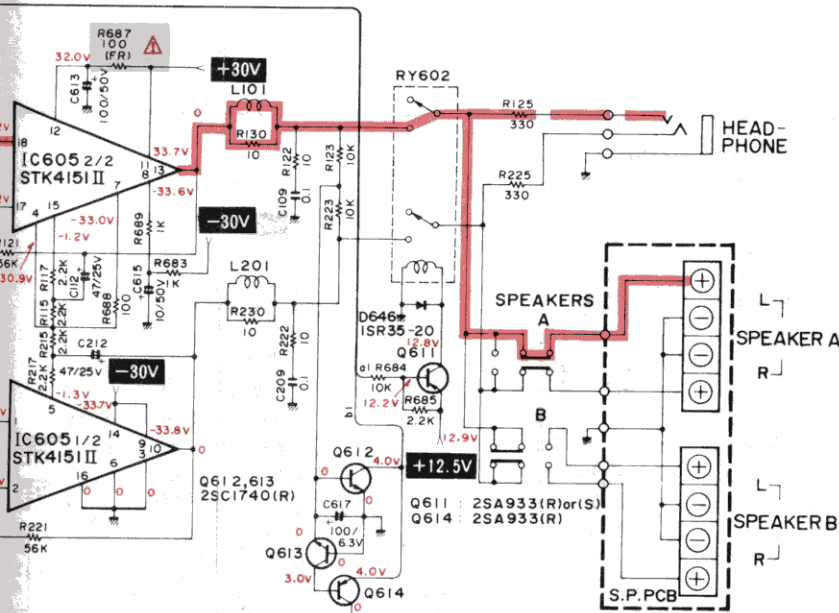

NOTE:

1. Unit of C and R

- C No-symbol; μ F
- P-symbol; PF
- R No-symbol; Ω
- K-symbol; k Ω
- M-symbol; M Ω

Wattage for all unspecified resistor are 1/4W.

2. Voltage are those measured with DC 1M Ω digital voltmeter.

3. **▲** and **▲** indicates components which are critical for continued safety and performance of this unit. Replace only with components of the same type as specified.

4. This circuit diagram may be changed due to circuit improvement.

TRANSISTOR

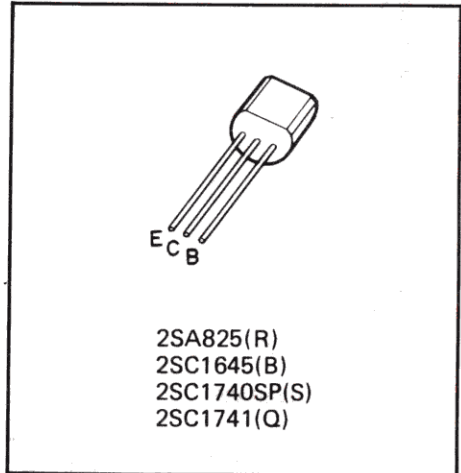

- 2SA825(R)
- 2SC1645(B)
- 2SC1740SP(S)
- 2SC1741(Q)

SCHEMATIC DIAGRAM (2/2)

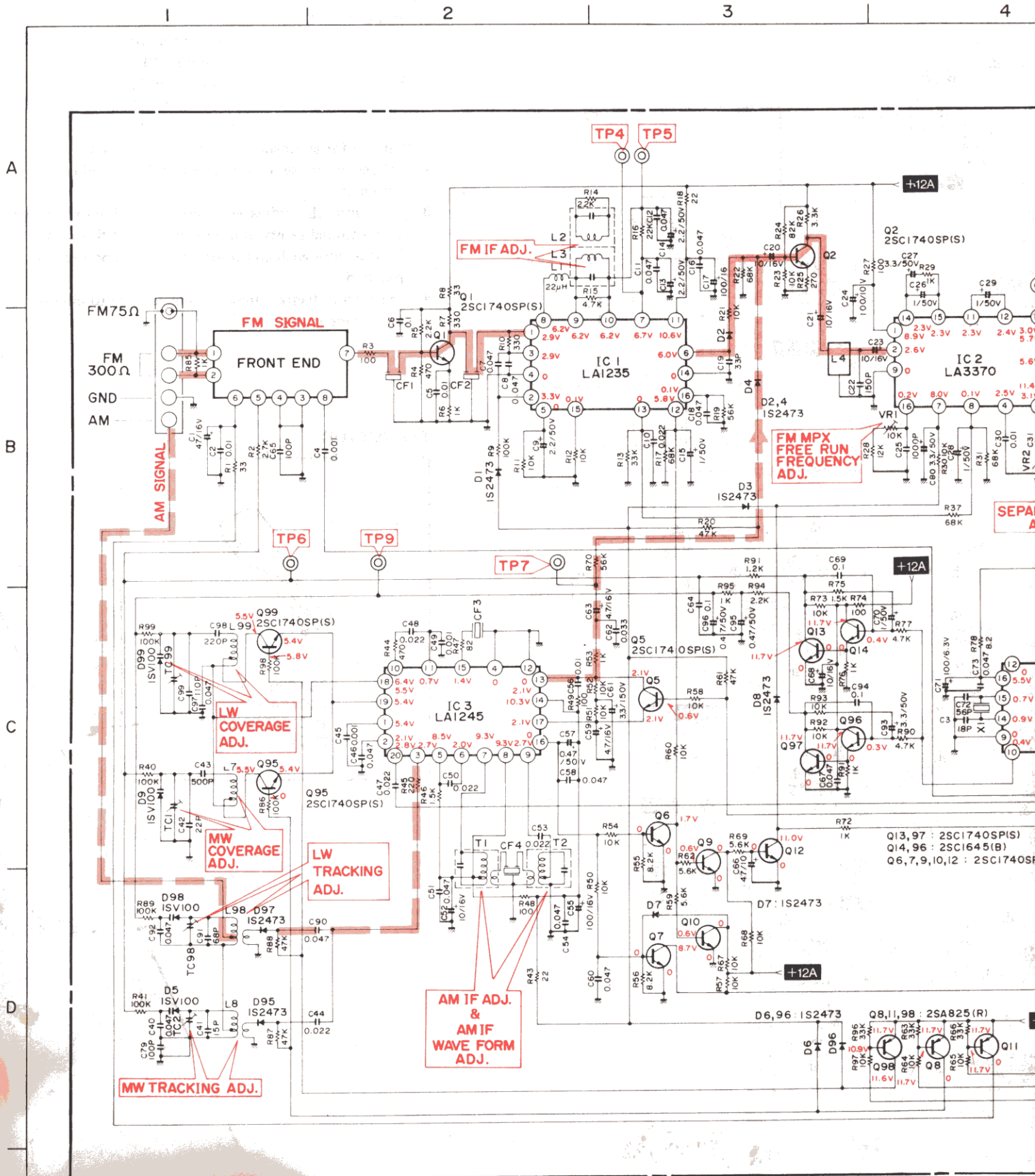

4

5

6

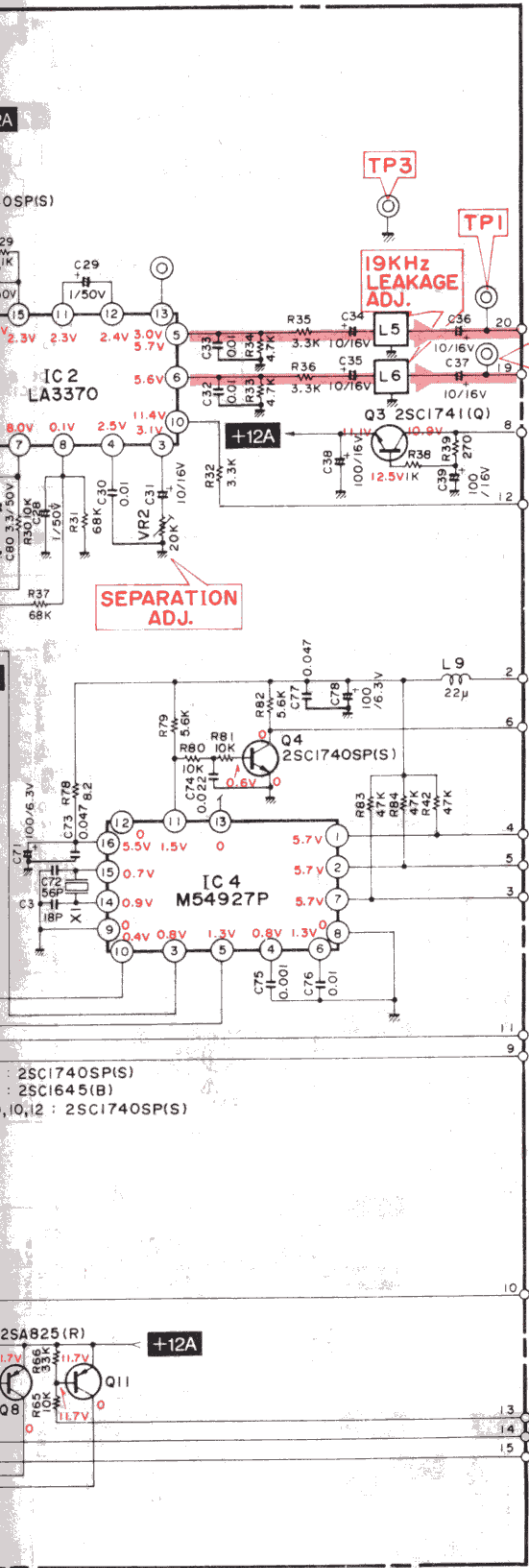

A

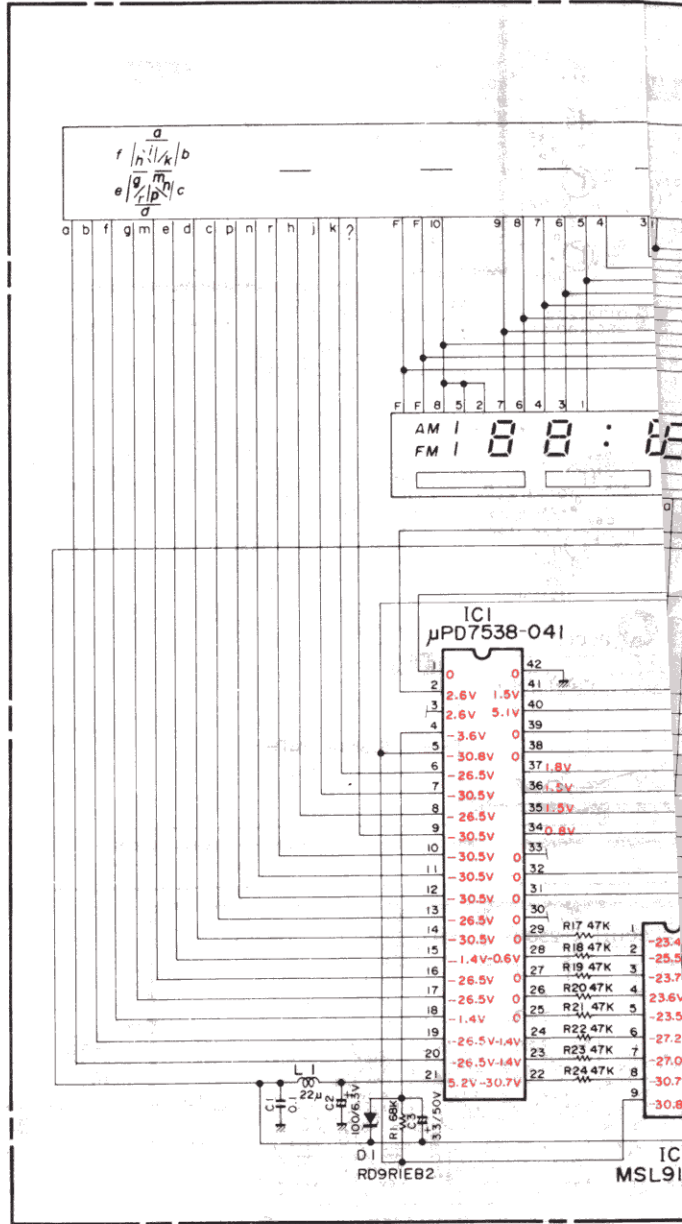

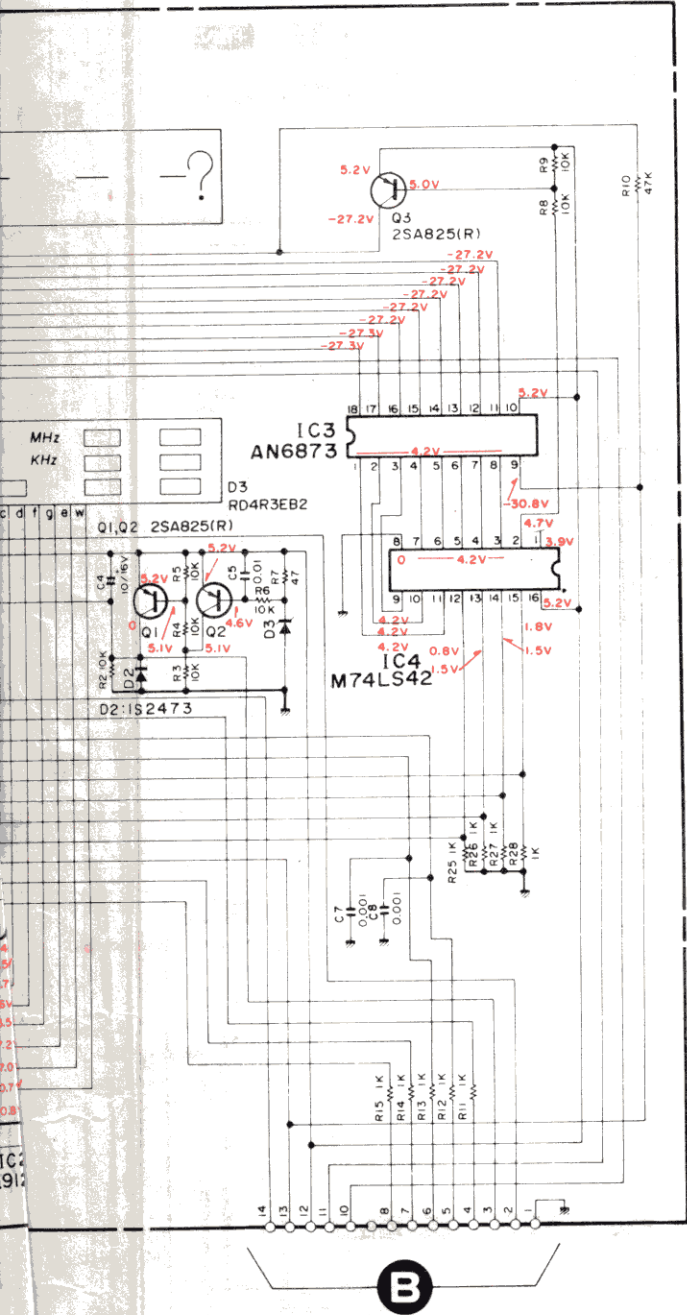

NOTE:

- 1. Unit of C and R
 - C No-symbol; μF
 - P-symbol; PF
 - R No-symbol; Ω
 - K-symbol; kΩ
 - M-symbol; MΩ
- Wattage for all unspecified resistor are 1/4W.
- 2. Voltage are those measured with DC 1MΩ digital voltmeter.
- 3. and indicates components which are critical for continued safety and performance of this unit. Replace only with components of the same type as specified.
- 4. This circuit diagram may be changed due to circuit improvement.

TRANSISTORS

2SA933(R) or (S)
2SC1740(R) or (S)
2SC1740L(S)
2SC2878(B)

2SB889(R) or (Q)
2SD1189(R) or (Q)

2SA934(R) or (Q)

2SA1115(E) or (F)

2SB941(P) or (Q)

2SA885(R) or (S)
2SC1567(R) or (S)

SCHEMATIC DIAGRAM (1/2)

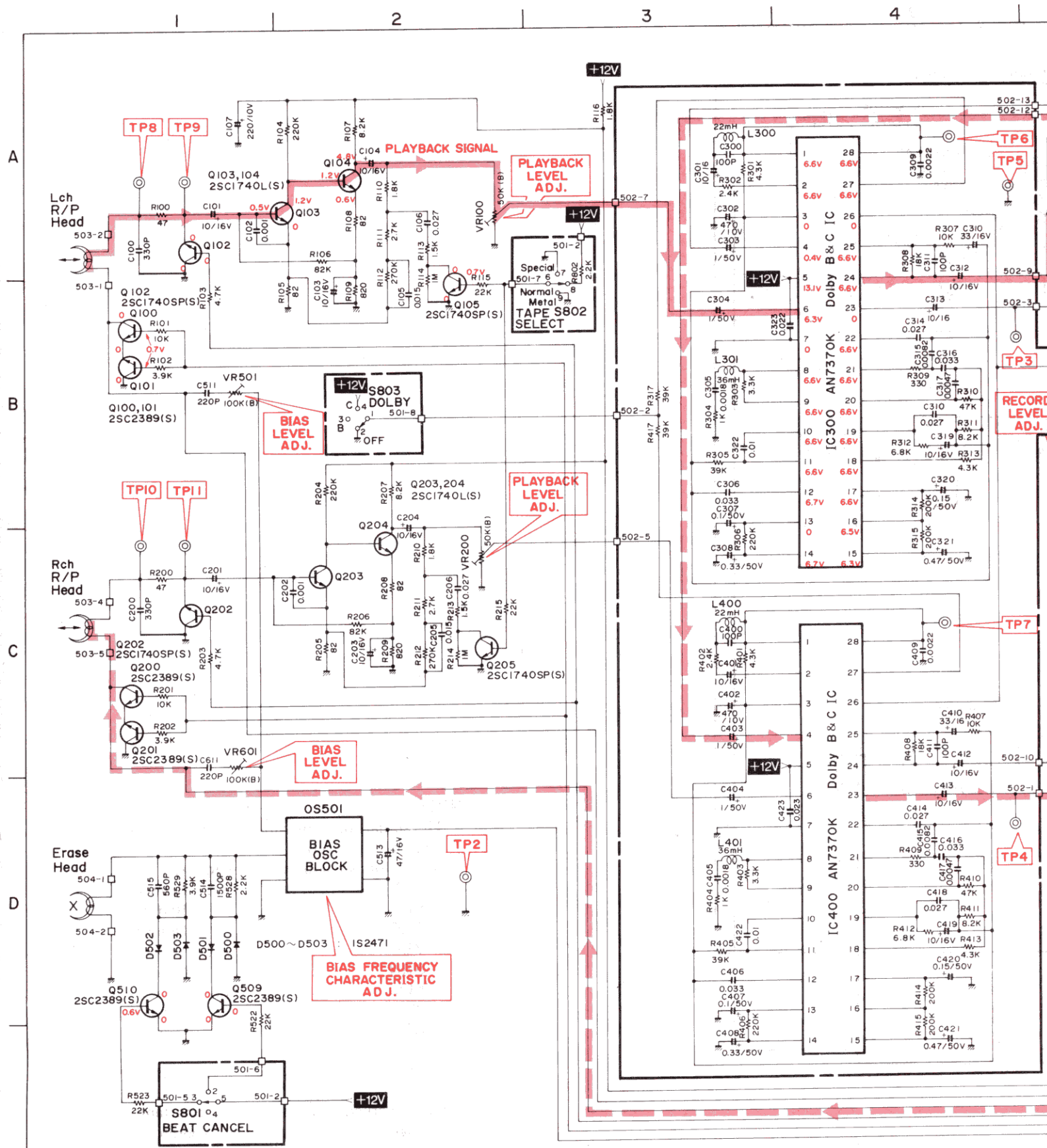

5

6

7

8

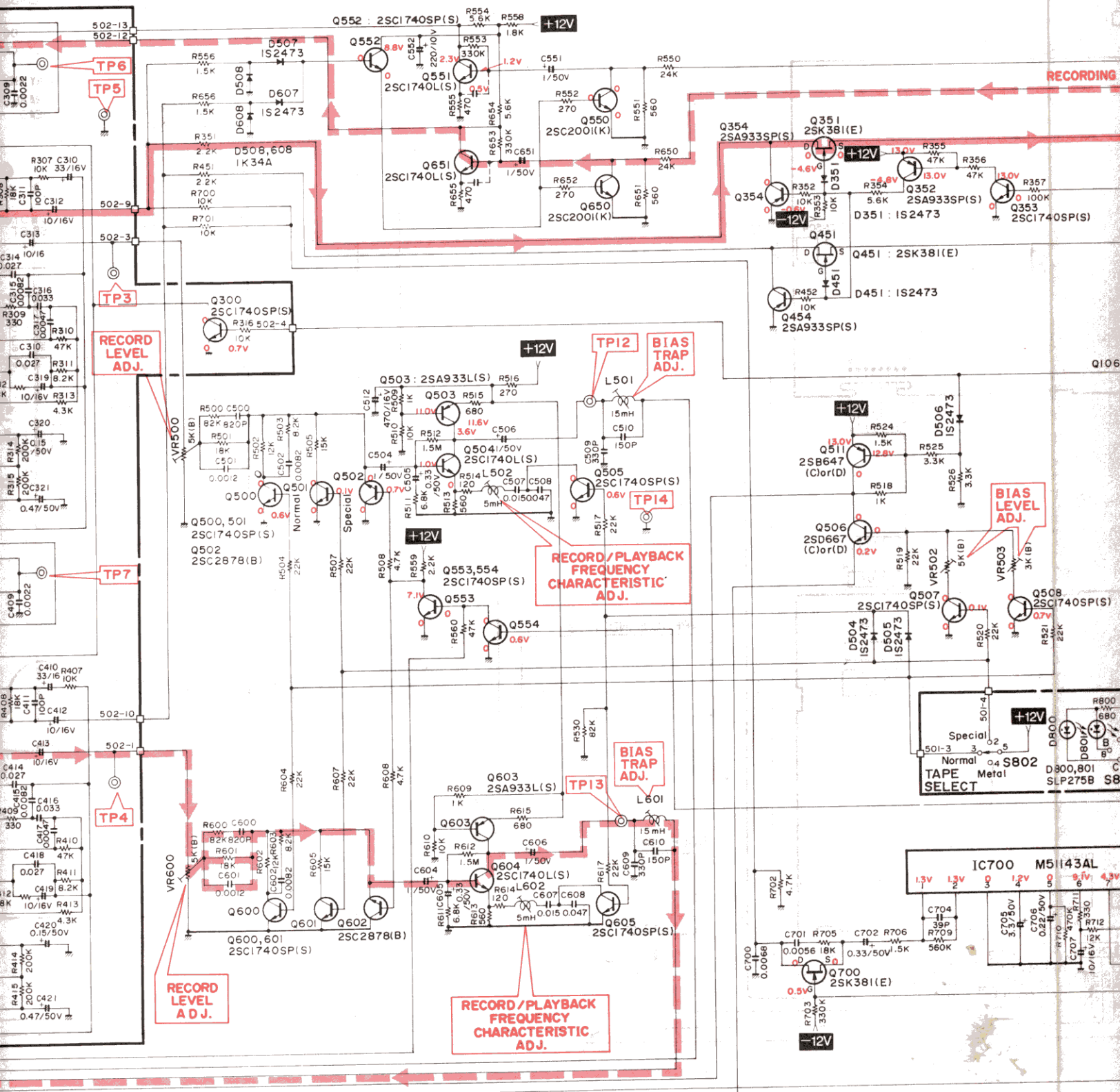

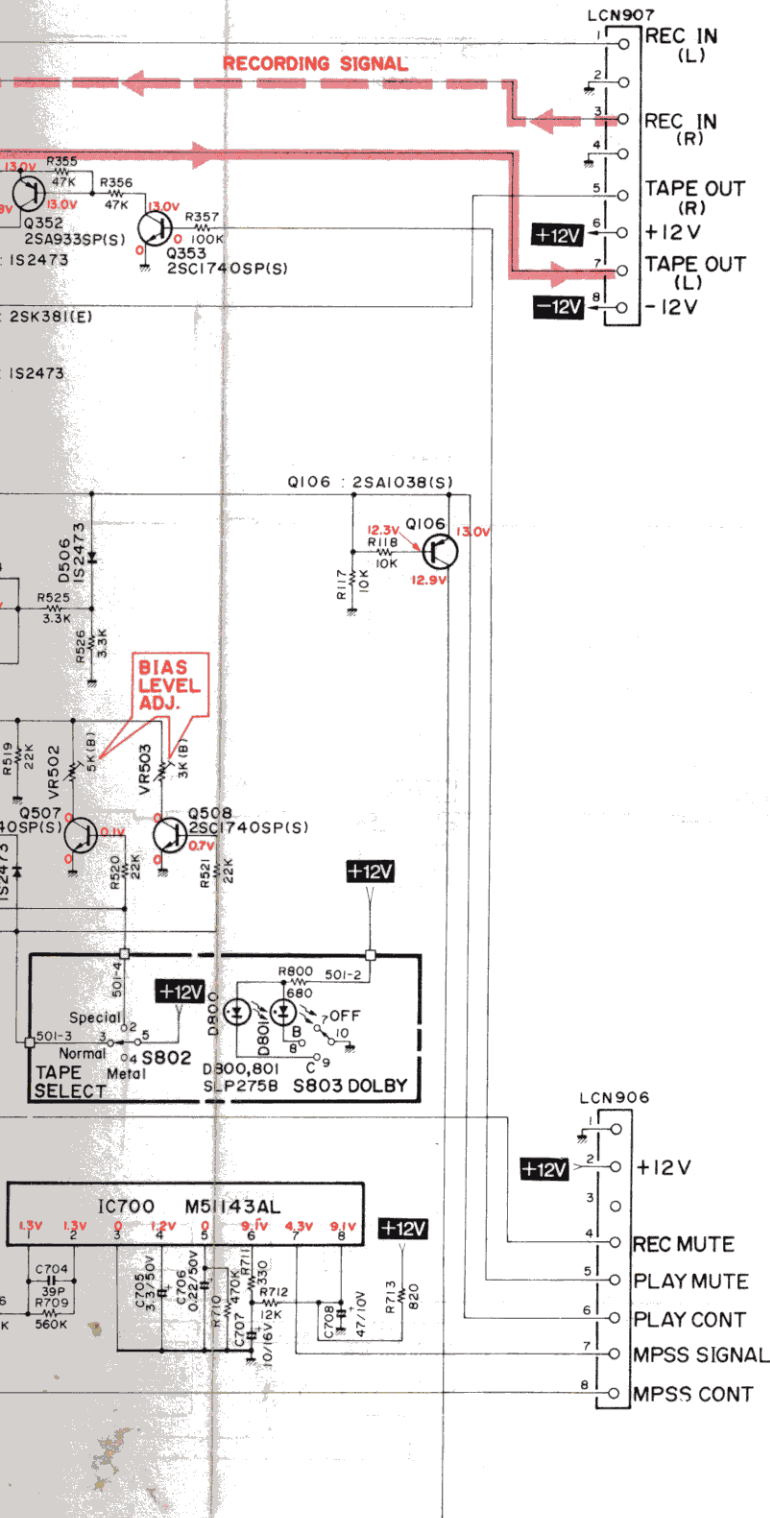

NOTE:

1. Unit of C and R

C No-symbol; μF

P-symbol; PF

R No-symbol; Ω

K-symbol; k Ω

M-symbol; M Ω

Wattage for all unspecified resistor are 1/4W.

2. Voltage are those measured with DC 1M Ω digital voltmeter.

3. **■** and **▲** indicates components which are critical for continued safety and performance of this unit. Replace only with components of the same type and value specified.

4. This circuit diagram may be changed due to circuit improvement.

TRANSISTORS

2SA933L(S)
2SA933SP(S)
2SA1038(S)
2SC1740L(S)
2SC1740SP(S)
2SC2001(K)
2SC2389(S)
2SC2878(B)

2SB647(C) or (D)
2SD667(C) or (D)

2SK381(E)

SCHEMATIC DIAGRAM (2/2)

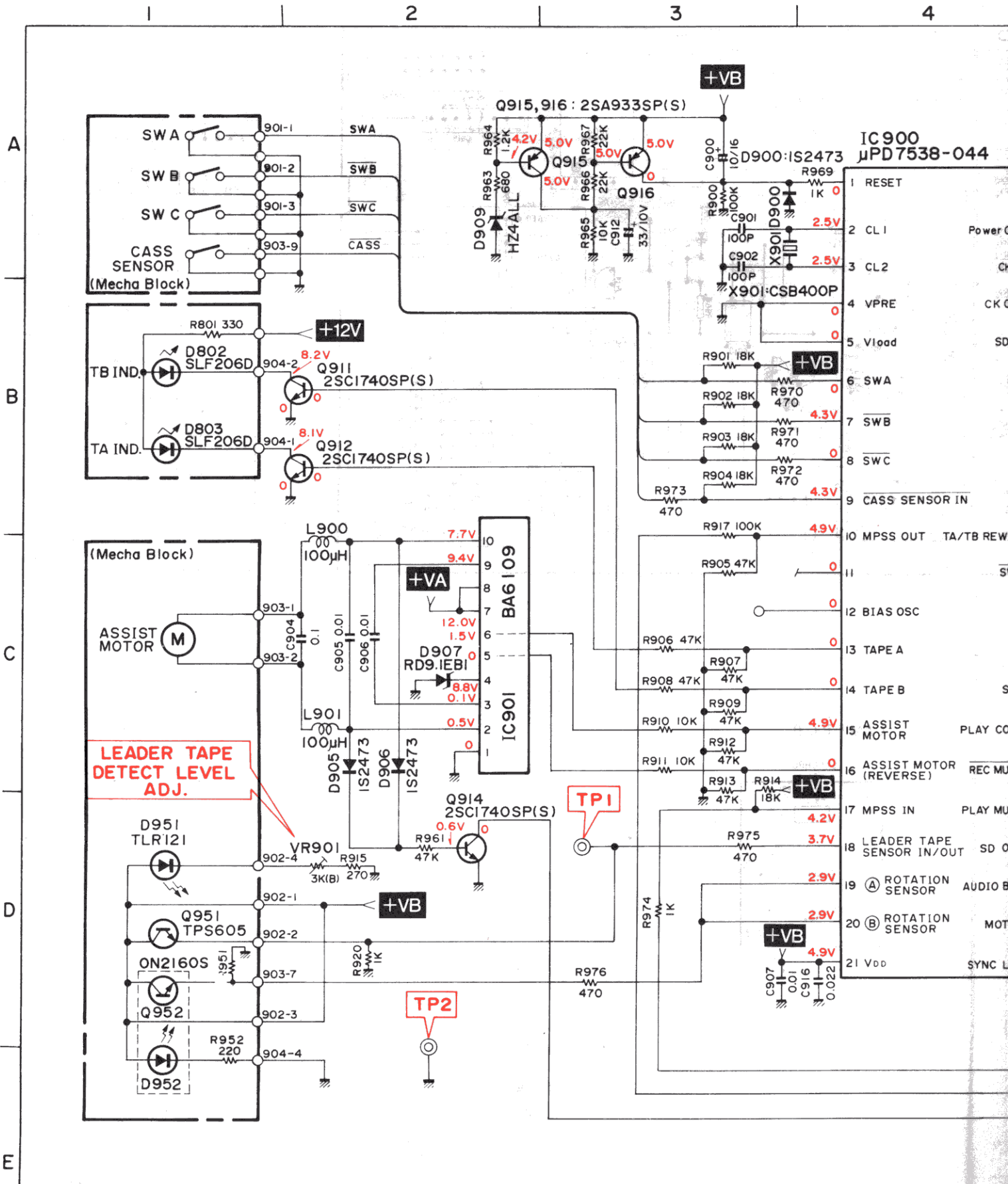

4

5

6

7

IC 900
μPD7538-044

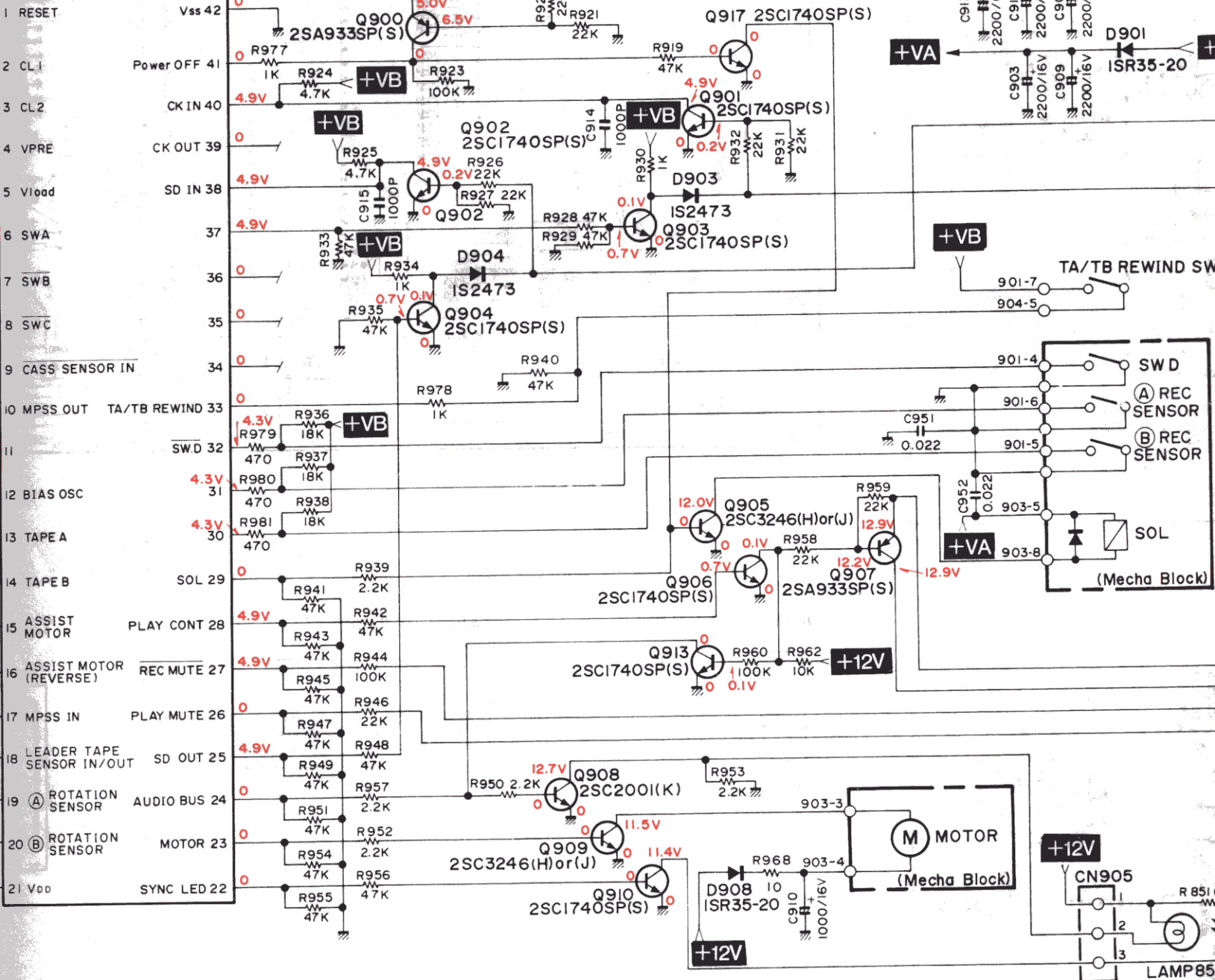

8

9

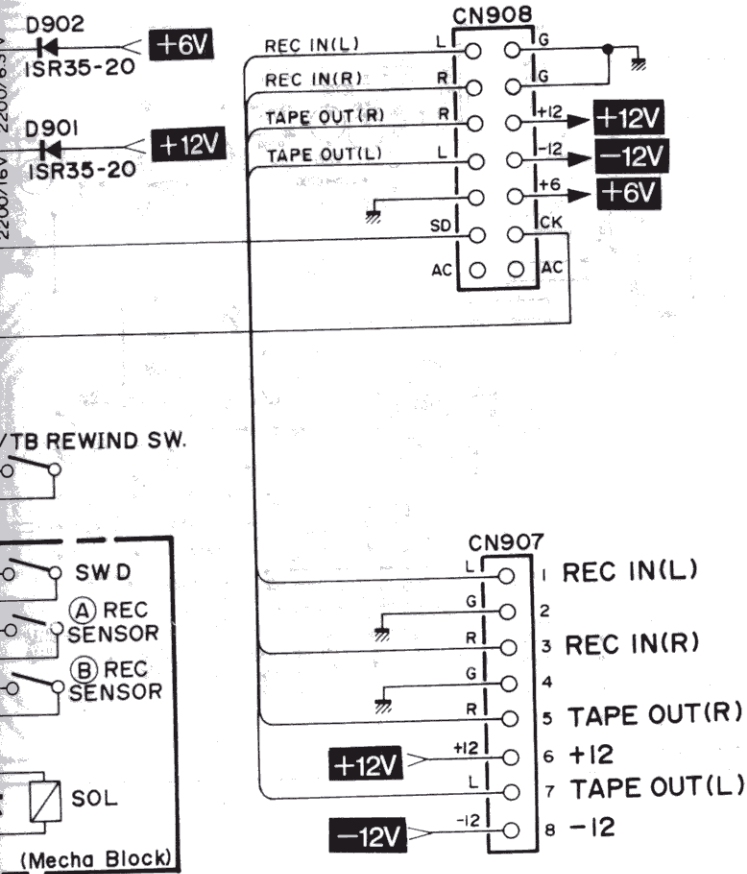

NOTE:

- Unit of C and R
 C No-symbol; μF
 P-symbol; PF
 R No-symbol; Ω
 K-symbol; $\text{k}\Omega$
 M-symbol; $\text{M}\Omega$
- Wattage for all unspecified resistor are 1/4W.
- Voltage are those measured with DC 1M Ω digital voltmeter.
- and ▲ indicates components which are critical for continued safety and performance of this unit. Replace only with components of the same type as specified.
- This circuit diagram may be changed due to circuit improvement.

TRANSISTORS

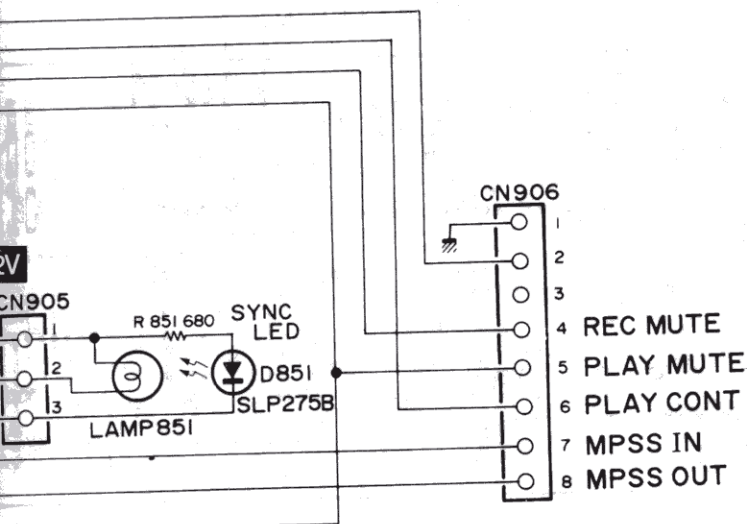
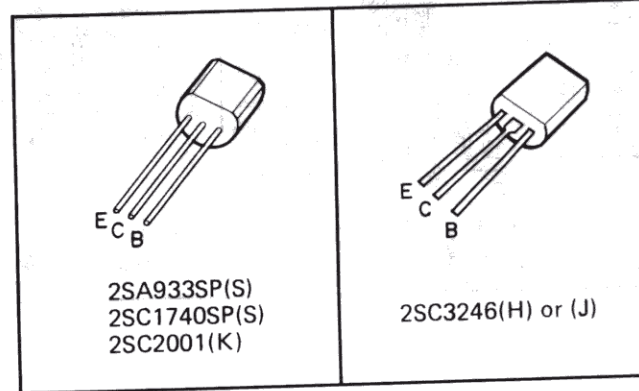

SCHEMATIC DIAGRAM

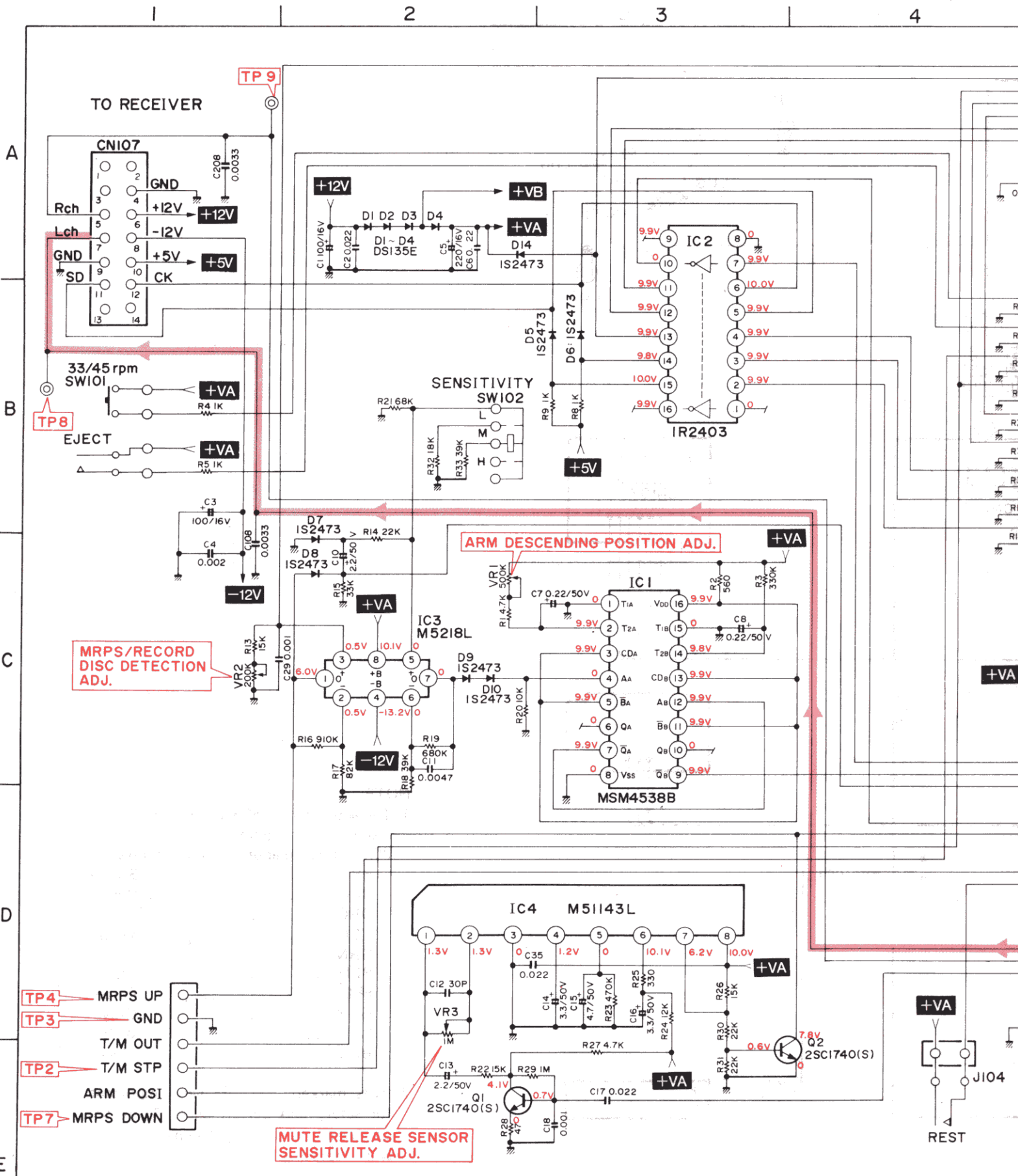

4 5 6 7 8

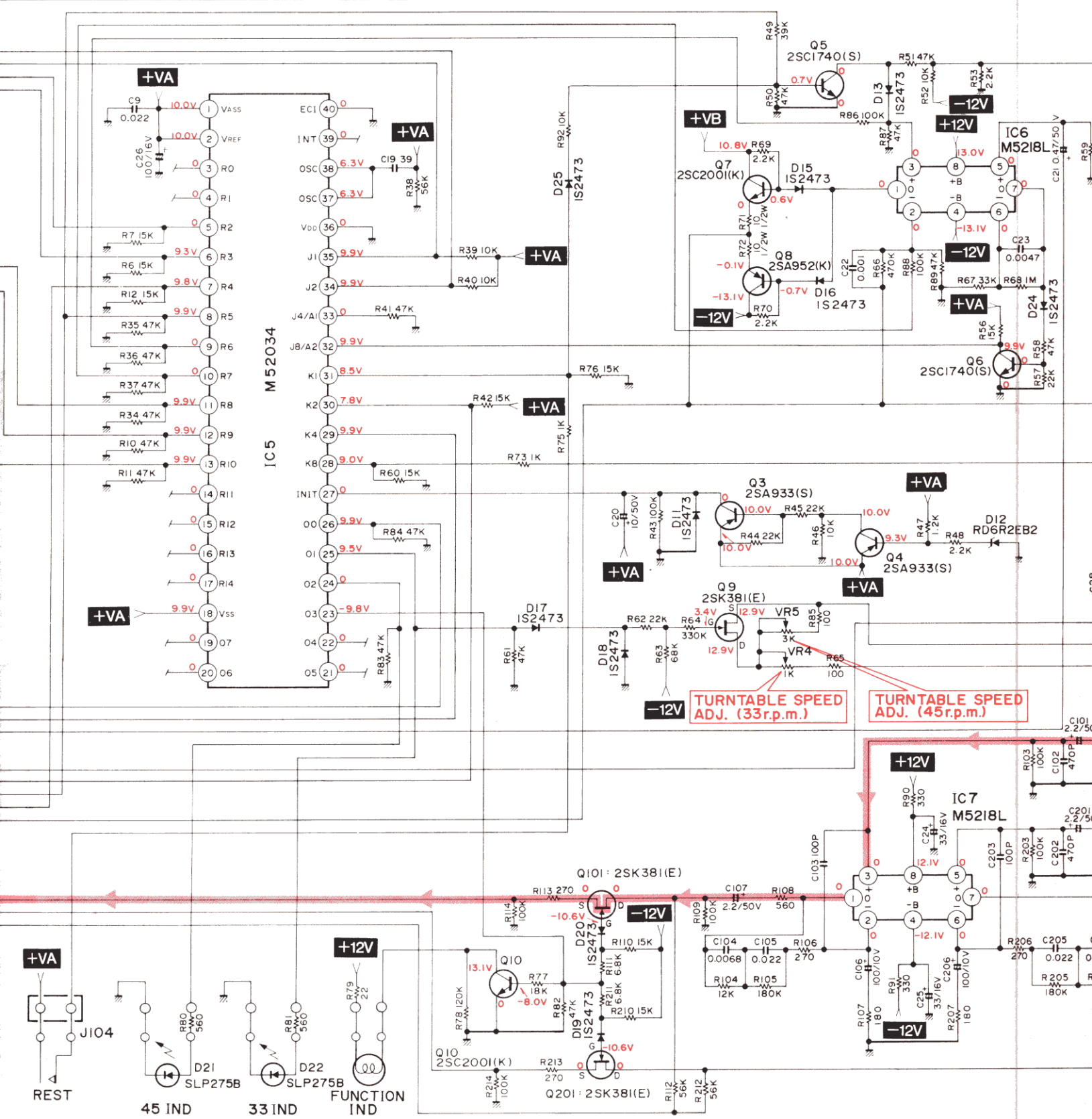

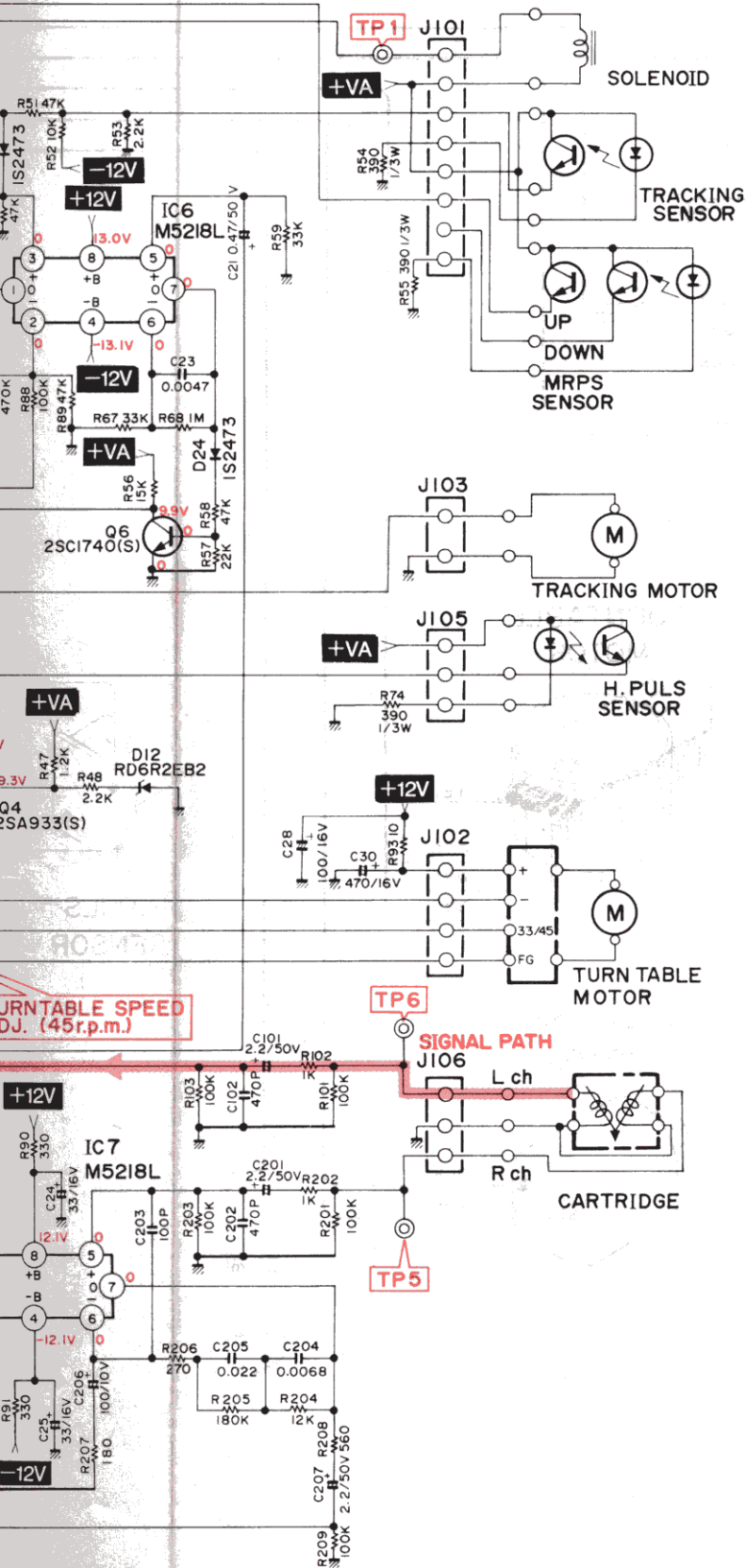

NOTE:

1. Unit of C and R

- C No-symbol; μ F
P-symbol; PF
- R No-symbol; Ω
K-symbol; k Ω
M-symbol; M Ω

Wattage for all unspecified resistor are 1/4W.

2. Voltage are those measured with DC 1M Ω digital voltmeter.

3. and indicates components which are critical for continued safety and performance of this unit. Replace only with components of the same type as specified.

4. This circuit diagram may be changed due to circuit improvement.

TRANSISTORS

